

# in.p3-110™



Waterproof protection, docking, connectivity  
& remote control for iPod on a spa!

## Owner's manual

Control your iPod from your spa keypad  
Seamless integration of your iPod to the waterproof audio  
and control systems of your spa!



*Aeaware*  
by gecko **3**®





## Table of contents

features.....	5
warnings .....	6
overview .....	8
installation .....	9
connections	
in.chant™ .....	11
in.tune II™ .....	12
placing iPod on the dock station .....	13
placing USB key or other MP3 player (optional).....	14
specifications.....	15





## in.p3-110™

Inner waterproof protection, docking, connectivity and remote control for iPod on a spa

The in.p3-110™ is a waterproof enclosure installed on a spa side panel that provides inner protection for your iPod. Besides protection against water, it docks, connects and enables remote control of your iPod. The in.p3-110™ is the perfect solution to safely integrate your iPod to the waterproof audio system of your spa.

Used with our digital media player in.chant™, you can control your music from the edge of the spa while being in the water with our sleek in.k455™ waterproof keypad. With optional USB/Aux connector, you can read MP3 file from a USB memory stick or from other MP3 players.

Used with our AM-FM receiver/CD player in.tune II™, you can control your music from our in.k600™ multi-function keypad, dedicated wired remotes such as in.k175™ or in.k455™, IRMT-4 wireless remote, or again directly from the faceplate of your in.tune II™.

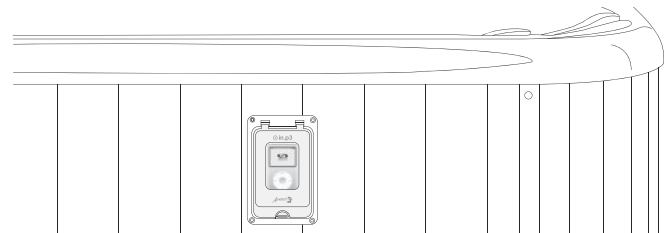

**WARNINGS:**

Important safety instructions

FAILURE TO COMPLY WITH THE FOLLOWING WARNINGS MAY SIGNIFICANTLY SHORTEN PRODUCT'S LIFE, AND LEAD TO FAILURES.

- The PRODUCT (including cables) cannot be modified or altered in any way without prior written approval from the manufacturer. Such alterations or modifications will void warranty and relieve Gecko Alliance Group from any liability.
- Use of this PRODUCT outside of its technical specification will void the warranty and Gecko Alliance Group liability.
- The PRODUCT should be serviced by qualified personnel only. There are no user serviceable parts inside.
- Always install the PRODUCT according to the instructions provided.
- This PRODUCT must ONLY be used with Portable Battery Powered iPod device.
- This PRODUCT must always be connected to an audio system protected by an approved ground-fault circuit interrupter (GFCI) or residual current detector (RCD.) Always check local electrical codes for approved GFCI and RCD types.
- This PRODUCT must be installed in a location that will force the spa user to exit the spa to use this product.
- Always keep the door closed between connection or disconnection of the iPod device.
- If the PRODUCT is physically damaged, the user must not use the PRODUCT. Professional servicing is required.
- Do not let water pour on the docking connector while connecting or disconnecting the iPod device.
- Never immerse the PRODUCT.
- This control is certified as a component only. The finished product which will incorporate this control should be certified by the proper agency as a finished product. In no circumstances should the fact that the control is certified as component be considered sufficient for the finished product to comply with certification requirements. The manufacturer is solely responsible for ensuring that the finished product complies with all applicable laws and regulations.

**WARNINGS:**

Important safety instructions

- This PRODUCT must be connected only to suitable audio system approved by Gecko Alliance Group.
- The low-voltage cables of this PRODUCT should be routed separately from high-voltage wires/cables and accessories.
- By nature, electronic devices are sensitive to Electromagnetic Interference (EMI). This PRODUCT and its cables should be located away from high voltage wire/cable and accessories (such as Ozone Generator, Pump and the like).
- This control should always be installed with the proper orientation as per the specifications provided by Gecko Alliance Group.
- The PRODUCT is made of polymeric material. The PRODUCT must not be exposed to chemical substance such as (but not limited to) oils, greases, solvents, rust inhibitors, etc. For example, WD-40 and Loctite are not considered compatible.
- Beware, the application of some commonly used Cleaning Products that contain Ammoniac, Alcohols or Sodium hypochlorite could damage the PRODUCT, due to a negative chemical reaction between these ingredients and its plastic parts. Any other materials which may come in contact with the PRODUCT must be carefully evaluated under end use conditions for compatibility.
- This PRODUCT should be disposed of in accordance with the local waste disposal legislation in force.
- The spa wall structure must be strong enough and provide firm support for this PRODUCT. Reinforce spa panel structure if necessary before installing this PRODUCT.
- iPod is a trademark of Apple Inc., registered in the U.S. and other countries.
- Gecko Alliance Group shall not be liable for any incidental, special or consequential cost or damages incurred by the purchaser or others, including without limitation, damages for lost profits, goodwill, interruption of business, or any other injury or damage not expressly covered under this limited warranty, including any device connected to this PRODUCT. However, this limitation on consequential damages shall not apply to damages for injury to the person.

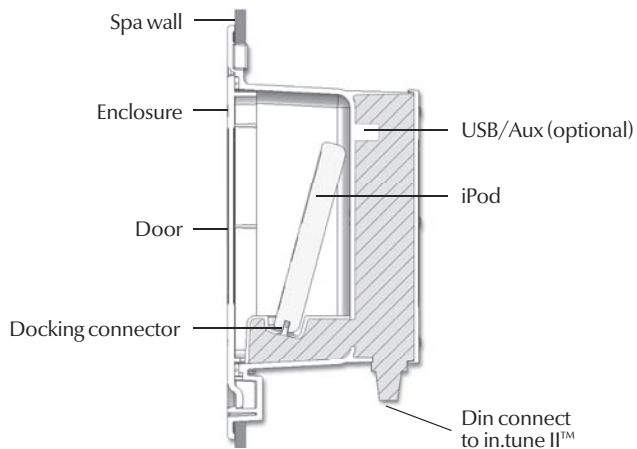

Side view in.p3-110™

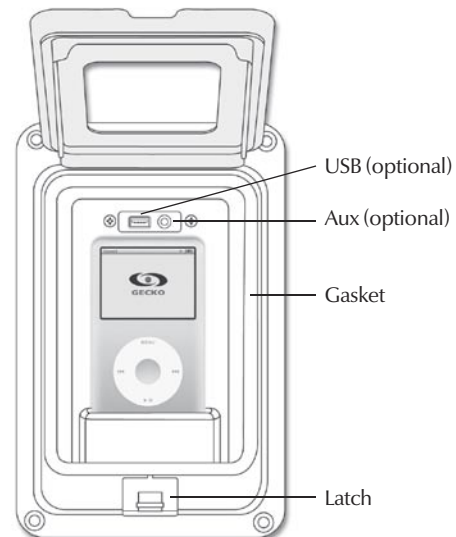

Front view in.p3-110™

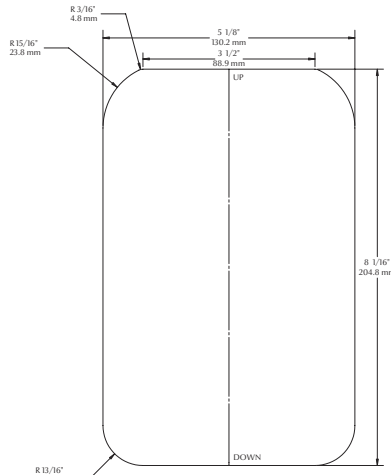

### Step 1

Using the drilling template supplied with the unit, determine the mounting location and then stick the template on the location.

Once the desired location is established, cut and remove the inside area on the template.

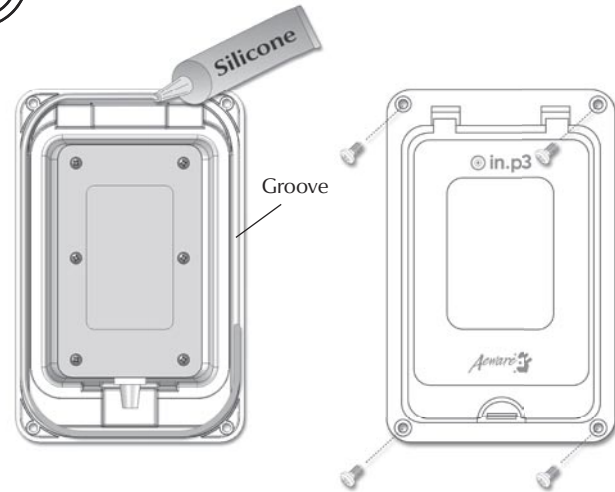

### Step 2

If the installation location is not perfectly even (e.g. wood surface), make a silicone joint between the installation location and the unit (fill the groove on the back of the unit with silicone).

Insert unit into the installation opening.

### Step 3

Then drill four  $1/8"$  (3 mm) mounting holes in the exact position according to the drilling template.

Use 4 - # 10 screws of the appropriate length with round, truss or pan head.



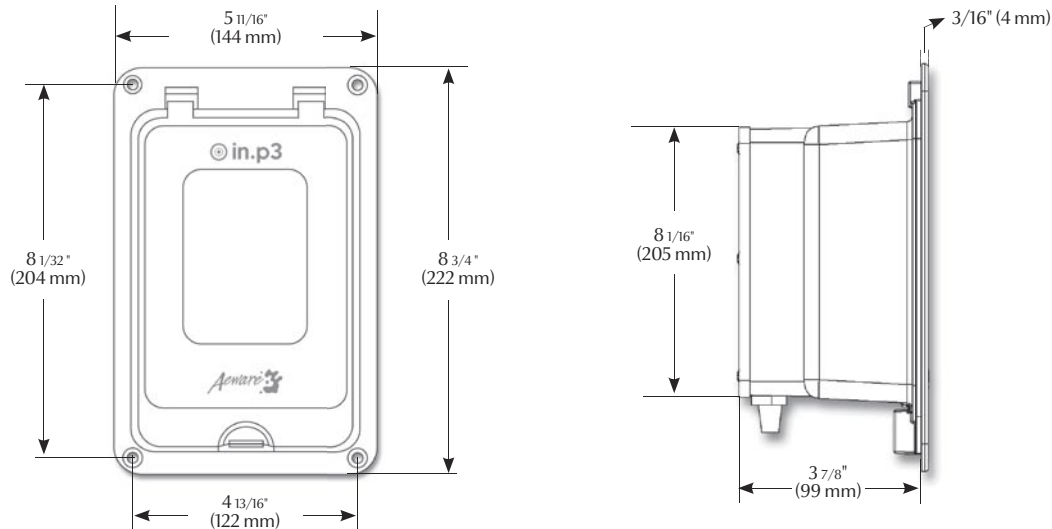

## in.p3-110™ dimensions

**Warning!**

The minimum recommended height to install the in.p3-110™ unit is at least 4" above the flooding zone. It's strongly recommended to install the in.p3-110™ unit as high as possible to facilitate user accessibility.

Carefully select the installation location making sure to avoid pipes, electrical wiring and other equipment when installing the in.p3-110™ unit.



### Connecting in.p3-110™ to in.chant™

The in.p3-110™ dock station comes with a 10 ft cable terminated with a 9-pin mini din connector. The in.p3-110™ with optional USB/Aux connectors comes with additional USB and RCA cables.

To connect the dock station simply insert the connectors into the receptacles as illustrated.

Model supported:  
See in.chant™ user manual.

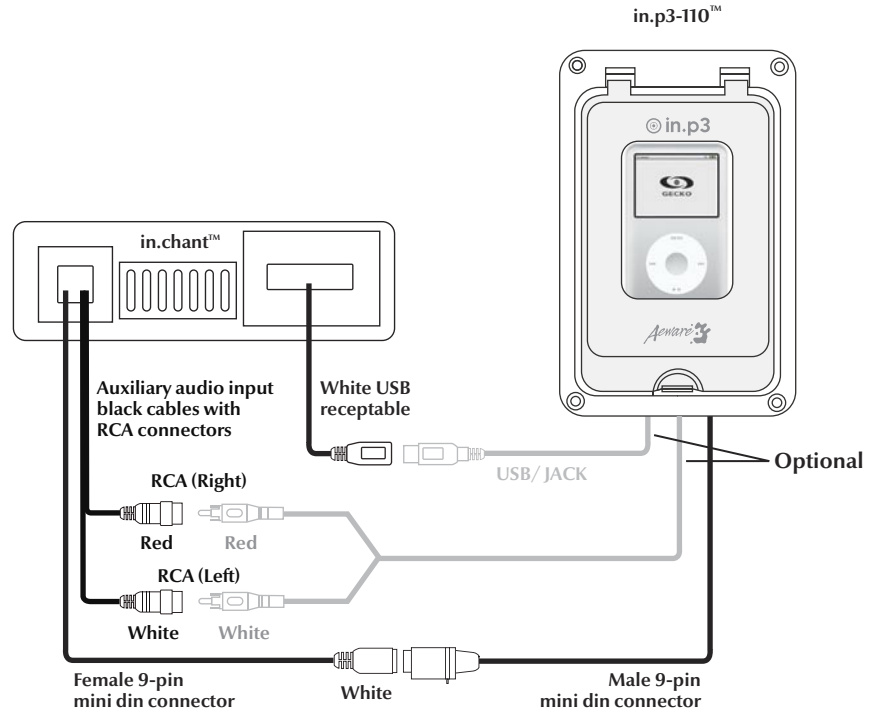

Note: It's not possible to directly control the iPod once connected to the in.p3-110™ docking connector.



## Connecting in.p3-110™ to in.tune II™

The in.p3-110™ dock station comes with a 10 ft cable terminated with a 9-pin mini din connector.

To connect the dock station simply insert the 9-pin mini din male connector into the 9-pin mini din receptacle as illustrated.

iPod model supported:  
See in.tune II™ user manual.

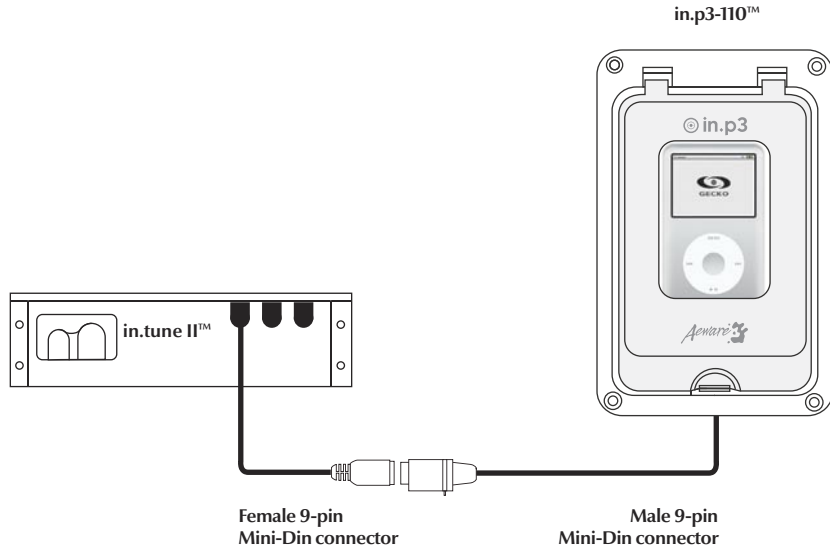

Note: It's not possible to directly control the iPod once connected to the in.p3-110™ docking connector.

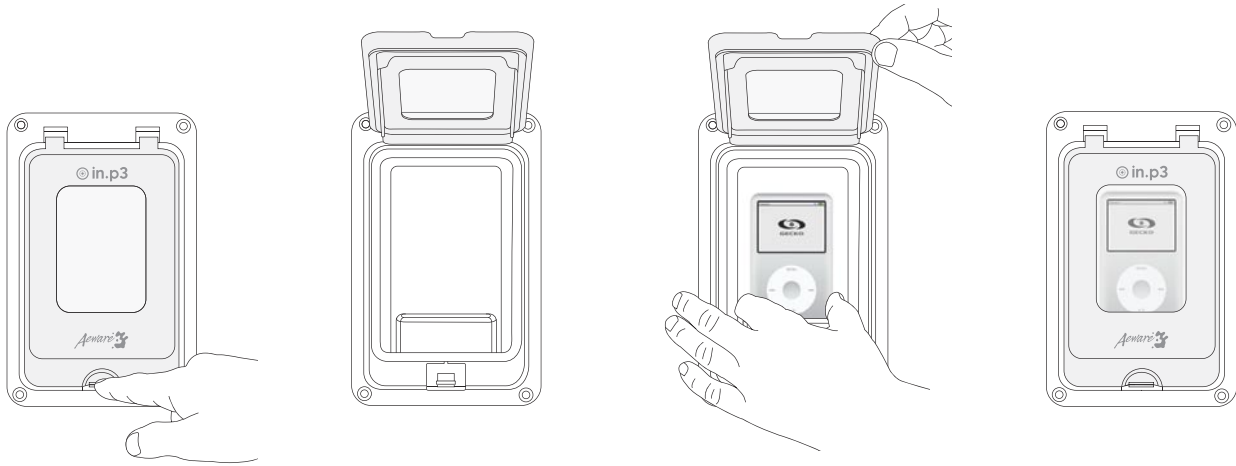

The iPod turns on automatically as soon as it's connected to in.p3-110™ docking connector. Power to the iPod is turned off when the iPod is removed from the docking connector. Gecko Alliance's logo and the note "Ok to disconnect" will be displayed on the iPod display when it's connected to the docking connector (the message displayed may vary depending on the model).

- Press downwards on bottom latch to release the door open.
- Open door compartment.
- Place your iPod inside and insert it on the docking connector.
- Close door.

### Battery charge

The in.p3-110™ unit also acts as an automatic recharging docking station for your iPod, it allows the owner/spa user to attach the iPod to the charging station and recharge the batteries while enjoying the music.

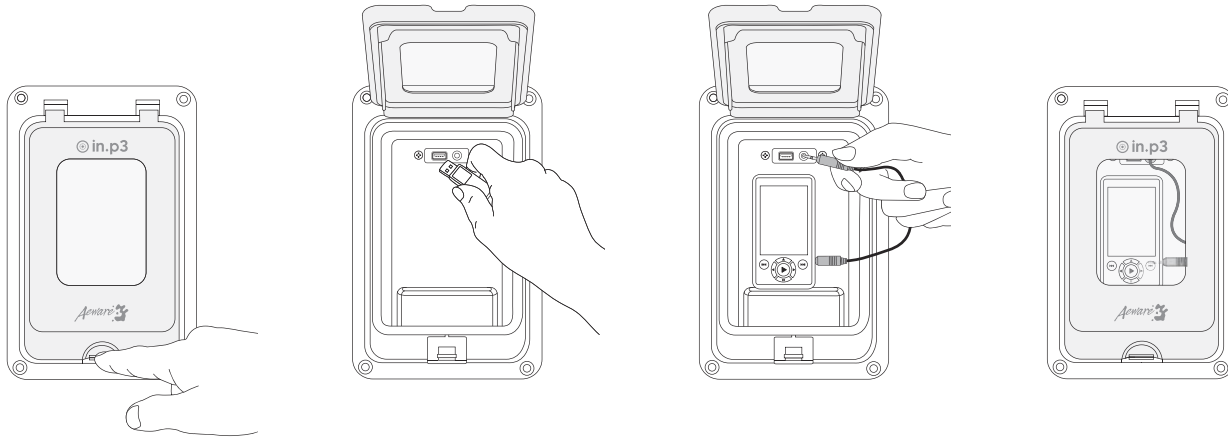

- Press downwards on bottom latch to release the door open.
- Open door compartment.
- Insert your USB key in the connector or
- connect a jack 1/8" to jack 1/8" cable between your MP3 player and the Aux connector in the dock station.
- Close door.

**General specifications:****Environmental:**

Operating temperature: -20°C (-4°F) to 50°C (122°F)

Storage temperature: -30°C (-22°F) to 60°C (140°F)

Humidity: up to 80% RH, non condensing

**Mechanical:**

Weight: 0.7 kg (1.6 lbs)

**Dimensions (W x H x D):**

144mm x 222mm x 99mm (5-11/16" x 8-3/4" x 3-7/8")

**Standards:**

UL 1563 Fifth Ed.

CSA No. 22.2 - 218.1-M89

EN/IEC 60335-2/A1=2004

EN/IEC 60335-1/A2=2006

EN 55014-1

EN55014-2

EN61000-3-2

EN 61000-3-3



9919-100811-B  
Rev. 03/11

© 2010 Groupe Gecko Alliance Inc.  
TM trade-marks of/marques de commerce de Groupe Gecko Alliance Inc.  
iPod is a trademark of Apple Inc., registered in the U.S. and other countries.

#### Gecko Alliance

450 des Canetons, Quebec City (QC) G2E 5W6 Canada, 1.800.78.GECKO  
9225 Stellar Court, Corona, CA 92883 USA, 951.667.2000

[www.geckoalliance.com](http://www.geckoalliance.com)

*Aeware*   
*by gecko*