

Quick Start Card

M-CLASS™ spa systems

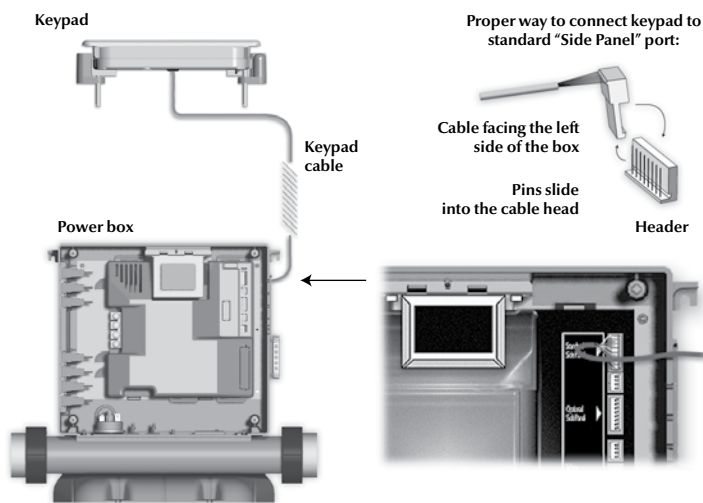

1- Connect all outputs & keypads



⚠ Clearance between Low and High Voltage conductors must be at least 1/4".

Connecting the temperature probe

The water temperature probe must be similarly connected to the port labelled "TEMP" on the board, with the cable following the same route as the main control keypad.



⚠ Make sure to connect all outputs with the proper output cable (120 or 240V), see wiring diagram inside the door.

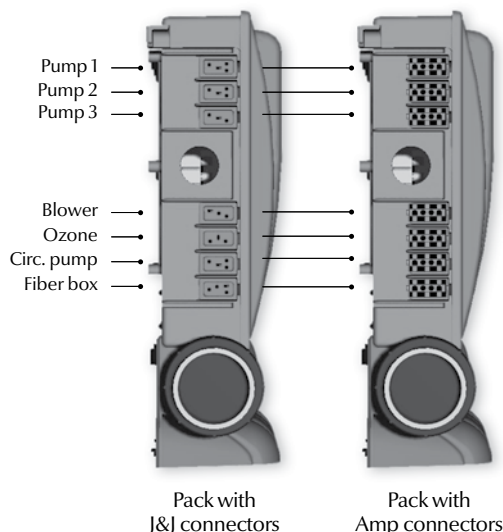

2- Install temperature probe

Temperature probe holder (TPH-1)

Our patented temperature probe holder has been specially designed to securely position a temperature probe holder to spa side panel.

Installing the temperature probe holder

The probe holder should be installed below water level and be easily accessible.

- 1- Select an appropriate location for the temperature probe holder.
- 2- Drill a 7/8" (22 mm) diameter hole in the spa wall.
- 3- Assemble and install the holder to spa wall as shown. Hand tighten nut by turning counter-clockwise (should be tight enough to prevent any water leakage).

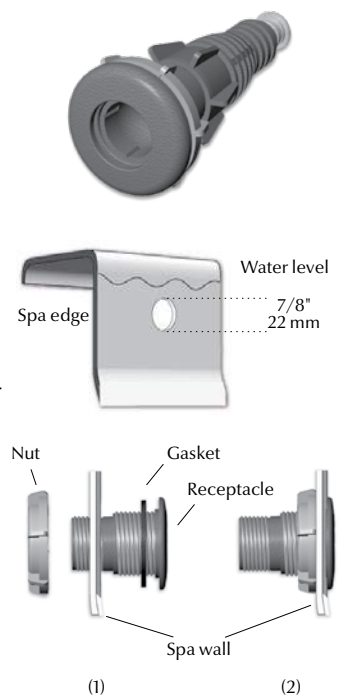

Installing the temperature probe

- 1- Insert probe into small end of strain relief and push completely through to other side. (a)
- Note: To ease the insertion, use a liquid and soap solution.
- 2- Force the stopper nut over the end of the strain relief so that it fits snugly. (b)
- 3- Insert the flat edge of probe into the strain relief. (c)
- 4- Insert probe assembly into the receptacle already installed on the spa wall and hand tighten. (d) Insert end-plug into small end of strain relief. (End-plug needs to be foamed over to prevent air temperature variations from affecting probe readings.)

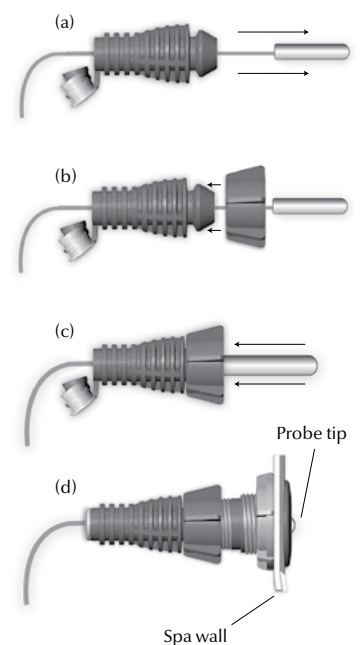

Note: Probe tip must slightly intrude into spa to ensure accurate temperature readings.

3- Select Jumper

Jumper configuration

Jumper number	Function	Position 1 (left)	Position 2 (right)
JMP-1	Input Current Mode	High current (HC) 48 amps max (60 amps breaker)	Low current (LC) 32 amps max (40 amps breaker)

JMP-2	SEE KEYPAD CONFIGURATION TABLE
JMP-3	
JMP-4	

Note: Factory default values in bold

Keypad configuration table

JMP-2		JMP-3		JMP-4		Keypad selected
Left	Right	Left	Right	Left	Right	
	X		X		X	K8 (8 keys)
	X		X	X		K47 (8 keys)
	X	X			X	K8 (10 keys)
	X	X		X		K4-k48 (8 keys)
X			X		X	K4 (10 keys)
X			X	X		K4 for 5 pumps (10 keys)

Note: Jumper 5 to 8 are not used.

IMPORTANT NOTE: Unfortunately, there are two different color standards for two-speed pump wires. Some use the red wire for the high speed winding and others use the black wire.

It is important to have the proper wiring configuration.

You can only test it when the system is ready to use. To do so, lower the set point below the water temperature to turn the pump off (it will take 30 secs. for the pump to go off). Press **Pump 1/Pump 2** key to manually turn on the pump. It should start in low speed and not high speed. If the pump starts in high speed, follow this procedure to correct the problem.

- 1) Turn the breaker off.
- 2) Locate the **Pump 1/Pump 2** connectors (P37 and P65/P22 and P35).
- 3) Using a pair of long-nose pliers, invert the connection of the black and red wires. Make sure the connectors are properly inserted.

3- Low Level Programming

Functionality

For K-8, K-8-10K & K-47: Hold On/Off key for 20s, 1st parameter will appear (Up/Down keys modify values).

For K-4-8K & K-48: Hold Economy key for 20s, 1st parameter will appear (Up/Down keys modify values).

For K-4-10K: Hold Economy key for 20s, 1st parameter will appear (Up/Down keys modify values).

Duration

For K-8, K-8-10K & K-47: Press On/Off key to display next parameter, system will reset after last parameter.

For K-4-8K & K-48: Press Economy key to display next parameter, system will reset after last parameter.

For K-4-10K: Press Economy key to display next parameter, system will reset after last parameter.

Parameter	Display	Value of x
1. Pump 1	P1 x	1 = Single Speed 2 = Dual speed
2. Pump 2	P2 x	0 = Not install 1 = One speed 2 = Two speed
3. Pump 3	P3 x	0 = Not install 1 = One speed
4. Pump 4	P4 x	0 = Not install 1 = One speed
5. Pump 5	P5 x	0 = Not install 1 = One speed
6. Blower	bL x	0 = Not install 1 = Install

4- Connect the pack to a GFCI breaker

Proper wiring of the electrical service box, GFCI box and pack terminal block is essential.

Refer to supplied wiring diagrams. Connections must be made by a certified electrician.

WARNING: TOTAL CURRENT OUTPUT CANNOT EXCEED TOTAL CURRENT INPUT RATING!

240 vac systems:

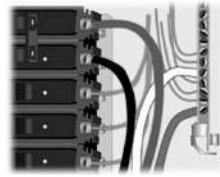

Electrical Box

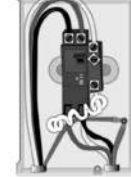

GFCI

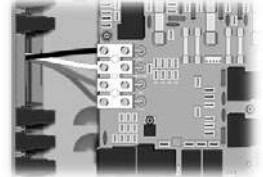

Pack Terminal Block

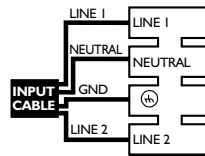

240 VAC input supply wiring

Parameter	Display	Value of x
7. Light	LI x	0 = Not install 1 = 12 VAC (single-intensity) 2 = 12 VAC (three-intensity) 3 = 120 VAC 4 = Internal fiber box
8. Ozone	O3 x	0 = Not installed 1 = Run during filter cycle only. 2 = Follow the circulation pump output
9. Circulation pump	CP x	0 = Not installed 1 = On during filtration and when heating (If PS associated) 2 = Always on 3 = Always on but off when 2 degree over set point
10. Filtration cycle	FC x	0 = Filtration cycle (with pump #1 or Circulation Pump (CP1)) 1 = Purge cycle (CP must be always on)
11. Pressure switch	PS x	0 = With pump one 1 = With the circulation pump
12. Time out output	To x	0 = 20 minutes 1 = 30 minutes 2 = 40 minutes
14. Current pump #1	C1 x (15)	Select the current of the pump#1 (1-15)
15. Current pump #2	C2 x (15)	Select the current of the pump#2 (1-15)
16. Current pump #3	C3 x (15)	Select the current of the pump#3 (1-15)
17. Current pump #4	C4 x (6)	Select the current of the pump#4 (1-6)
18. Current pump #5	C5 x (6)	Select the current of the pump#5 (1-6)
19. Current blower	Cb x (8)	Select the current of the blower (1-8)
20. Current heater	CH x (23)	Select the current of the heater (12-23)