



maelstrom[™]
MS-1 series

3hp - dual speed

The spa pump standard has been raised



Gecko motor

Welcome our brand-new Gecko custom made motor! We've put all our engineering knowledge at work to offer the best efficiency on the market. Thanks to the expertise that belongs to the rich history of Gecko, this pump offers outstanding performance in a compact design.



Moves water efficiently

Dynamics between pump components are complex. To ensure optimal output, Maelstrom pumps are engineered to run at their sweet spot.



Uncompromising quality

Built to last with the ultimate materials, Maelstrom pumps offer the best value on the market. Combined with the renowned North American Gecko quality and customer service, you obtain the best supply solution for your spa pumps.



3hp - dual speed

Model: MS-1-V25-2.5-2

Generic part number: 0800-200001

Electrical/Hydraulic

hp in	Input Rating	Frame Size	Speed	A MAX	H ¹ MAX (m)	Q ¹ MAX (LPM)
3	230V 50Hz	90	High Low	9,5 2,9	17 3,7	975 475

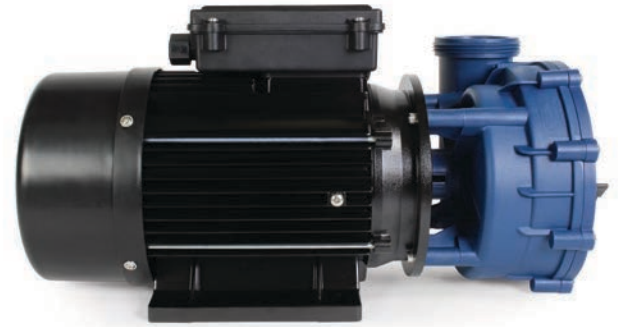

Weight: 17 kg (37,4 lbs)

Specification:

- Longer life capacitor with high temp. 85°C
- High ambient temperature run rated 60°C
- Maximum water temperature 50°C
- Sealed bearing
- Construction: PSC / Resistant Start
- Seal: Gecko high quality Universeal
- 60 mm (2") intake and discharge
- Insulation Class F thermally protected (155°C)
- IPX5 enclosure
- CE compliant
- AS/NZ Certificate #: SAA-201866-EA

Standard version includes:

- 2x white 60 mm union nuts with 60 mm slip tail pieces and O-rings
- Three wing nut drain plugs
- 2,4 m (96") cable with AMP plug
- Standard wet end position 0 o'clock
- Rubber anti-vibration mounts (4)

Dimensions

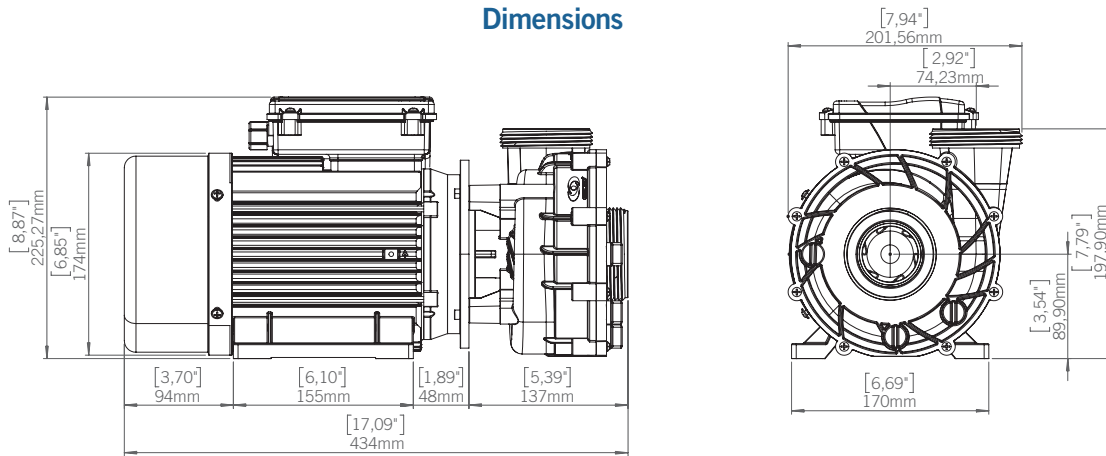

performance curves

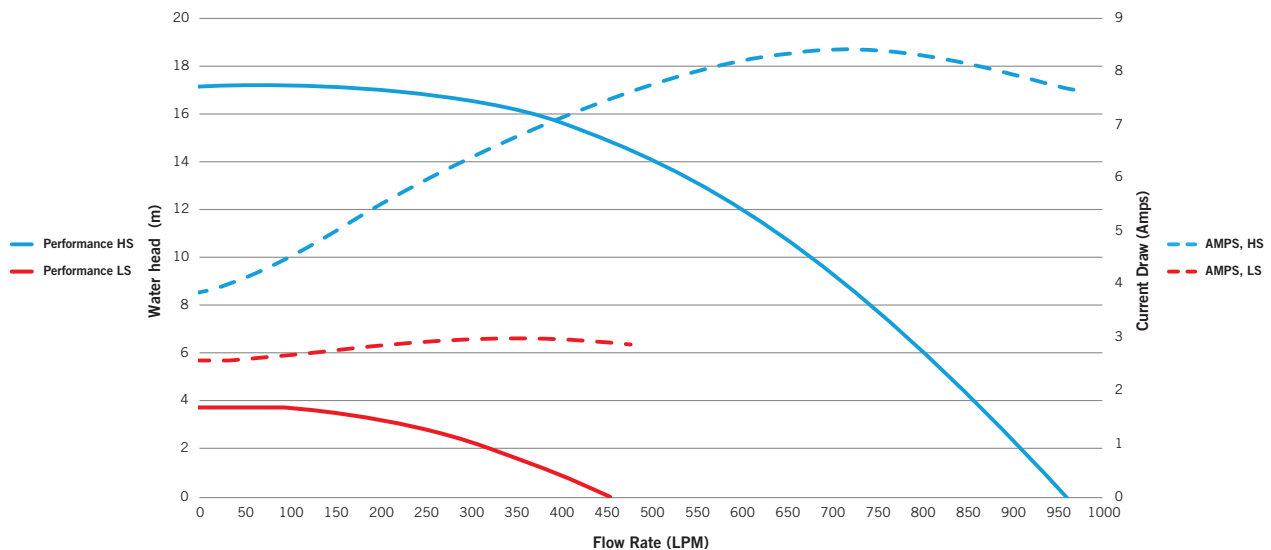

maelstrom™



450 des Canetons, Quebec City, QC Canada G2E 5W6, 800.78.GECKO, info@geckoal.com
www.geckoalliance.com www.geckopumps.com